

# Wiring 1 – PCB Ground

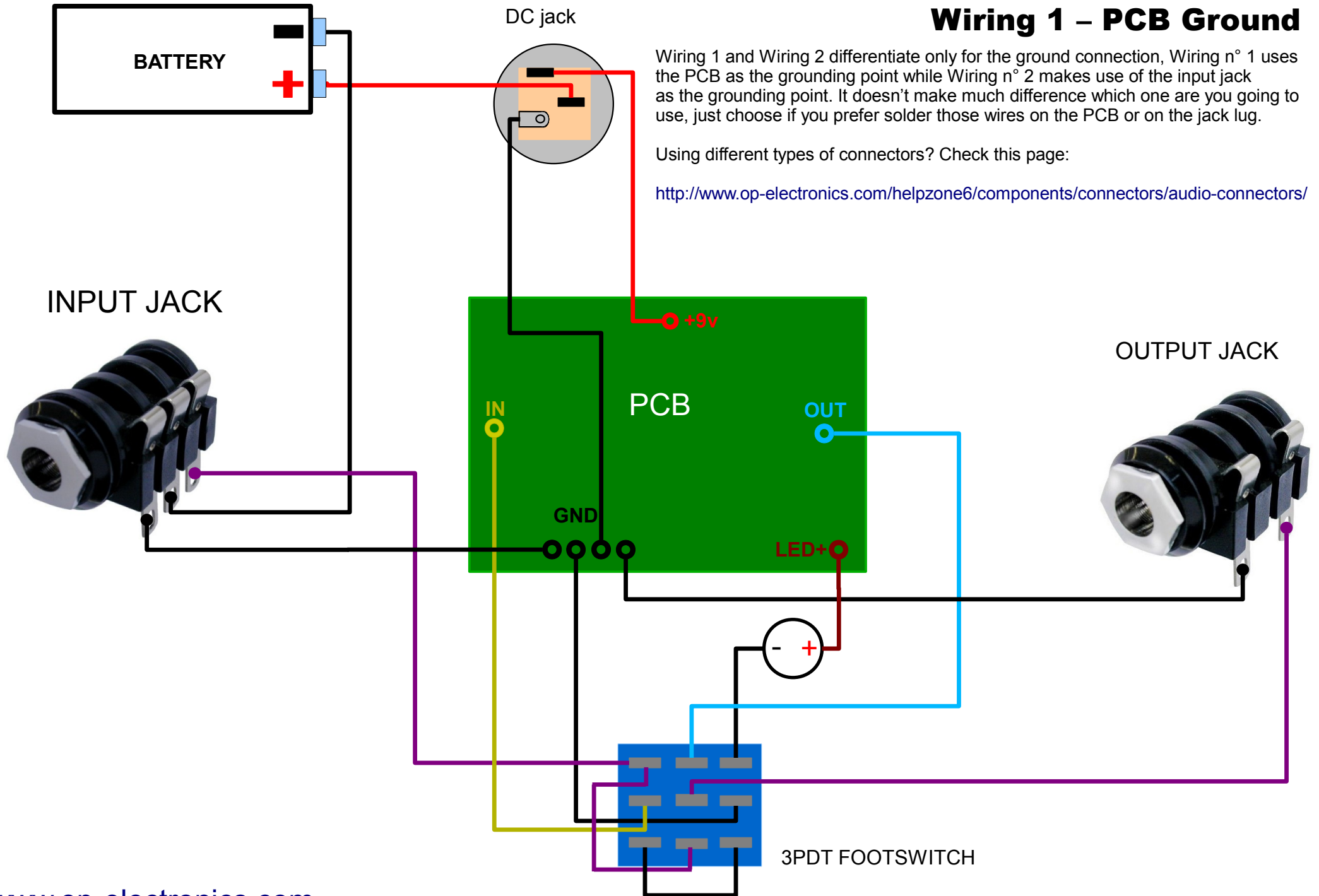

## Wiring 2 – jack ground

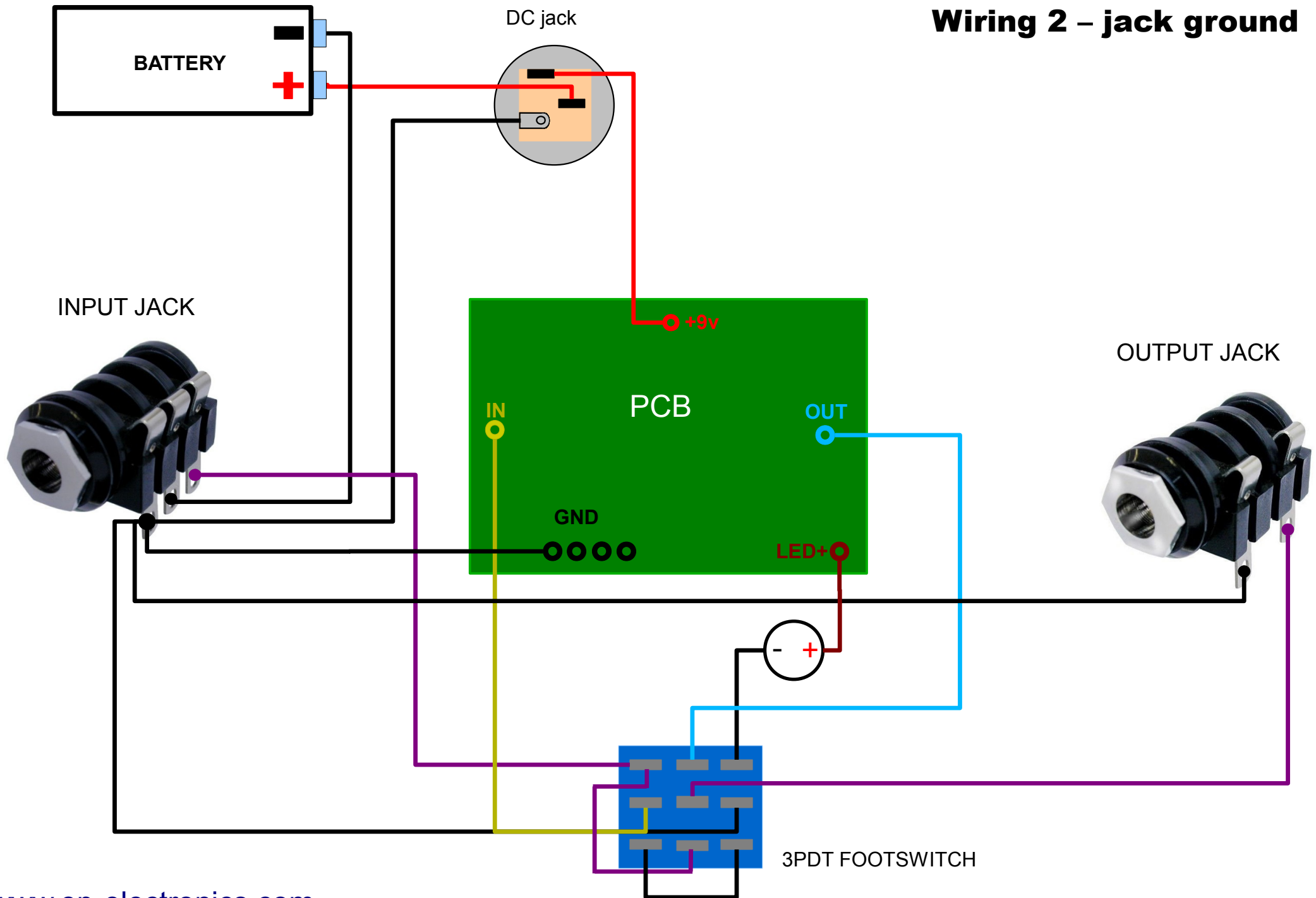

# Wiring 3

Some pcb have a SW pad connector in place of L+ and LED (A, K) pads.

